

HFDU08

Single Fingerprint Scanner

Hardware Datasheet



Version 0.3

Revision history

Date	Version	Description
2012-02-23	0.1	Beta release
2012-03-07	0.2	Revised

Contents

1. OVERVIEW	4
1.1 GENERAL FEATURES.....	5
1.2 BLOCK DIAGRAM.....	5
2. SPECIFICATION	6
2.1 OPTICAL FINGERPRINT SENSOR.....	6
2.2 ELECTRICAL	6
2.2 INTERFACE	6
3. DIMENSION	7

1. Overview

NITGEN HFDU08 is single fingerprint USB scanner equipped with fingerprint identification module FDU08 (FBI PIV Certified) to acquire high-resolution images with the most rugged and advanced optical sensor in comfortable, ergonomic design ensuring superior performance, accuracy and durability based on unique NITGEN Fingerprint Biometric Technology.

FDU08 consists of OPU08 sensor and USB Interface B/D.

- High-speed and Full-speed operation with bulk transfer mode
- Supported OS: Windows / Linux .



[Fig. 1] FDU08 fingerprint scanner module

1.1 General Features

	Description
Fingerprint Sensor	NITGEN OPU08
Image Size	260 (x) x 330 (y)
Image Resolution	500 [PPI]
Image Scale	256 Level Grayscale (8-bit)
Interface	USB 2.0, Plug & Play
Supply Voltage	5 ± 5% [V]
Current Consumption	Max. 120 [mA]
Operating Temperature	-20 ~ 60 [°C]
Storage Temperature	-20 ~ 70 [°C]
Operating Humidity	RH 10~90 %
Cable Length	1600 [mm]
Compliance	KC,CE,FCC,WHQL, UL, RoHS, FBI (IAFIS), FIPS201, India STQC

1.2 Block Diagram

FDU08 consists of USB interface B/D and OPU08 sensor module. USB interface B/D controls OPU08 sensor and transfers image data from OPU08 sensor to host computer such as PC or embedded device. FDU08 is powered by USB power.

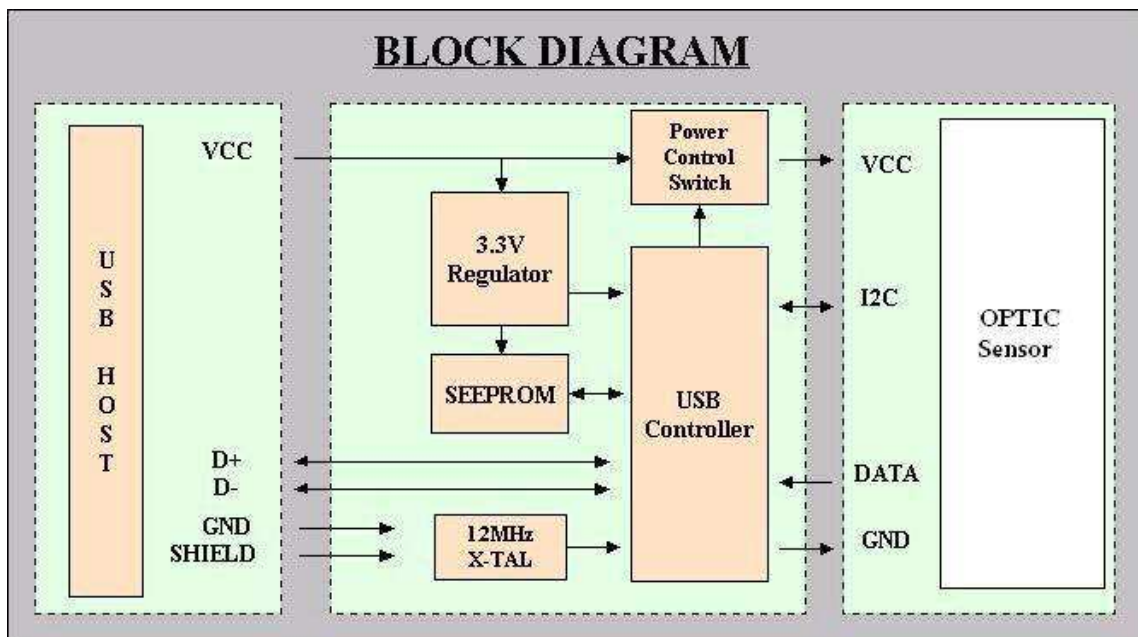

2. Specification

2.1 Optical Fingerprint Sensor

	Description
Hardness of prism surface	750Hk
Resolution	500 ± 10 [PPI]
Platen Area	16 mm (x) x 18mm (y)
Effective Sensing Area	13.2mm (x) x 16.8mm (y)
Effective Pixel Array	260 x 330
Image Aspect Ratio	0.788 (x / y)
Non-linear Distortion of Image	Less than 1.8%
Resolution	8bits/pixel (256 Gray Level)
Light Source	Green LED
Light Wave Length	470 [nm]

2.2 Electrical

	Description
Power Source	Bus Powered
Current Consumption (Normal)	About 120 [mA]
Current Consumption (Standby)	< 5 [mA]
Current Capture(Capture Operation)	Max 180 [mA]
ESD Tolerance	< +/-8 [kV]

2.2 Interface

	Description
Interface	Universal Serial Bus Revision 2.0
Transfer Type	Bulk Mode
Communication Speed	High Speed(480Mbps) / Full(12Mbps)
Image Capture Speed (High Speed)	About 130ms/Frame
Image Capture Speed (Full Speed)	About 530ms/Frame
Supported OS	Window series : Window 7, Vista, XP, 2000 Window CE 5.0, 6.0, Server 2003, 2008 Linux series : Kernel Version 2.6.x or higher

3. Dimension

