

# 2 Inch Thermal Printer



## INTRODUCTION

The 2 Inch Thermal Panel Printer Module which enables the OEM users to avoid hassles like mounting mechanism, paper roll, developing control board etc. It has following features.

- Compact size
- Silent printing
- Easy paper loading
- Easy Panel Mounting
- High resolution (203 dpi)
- Low noise

## FRONT VIEW

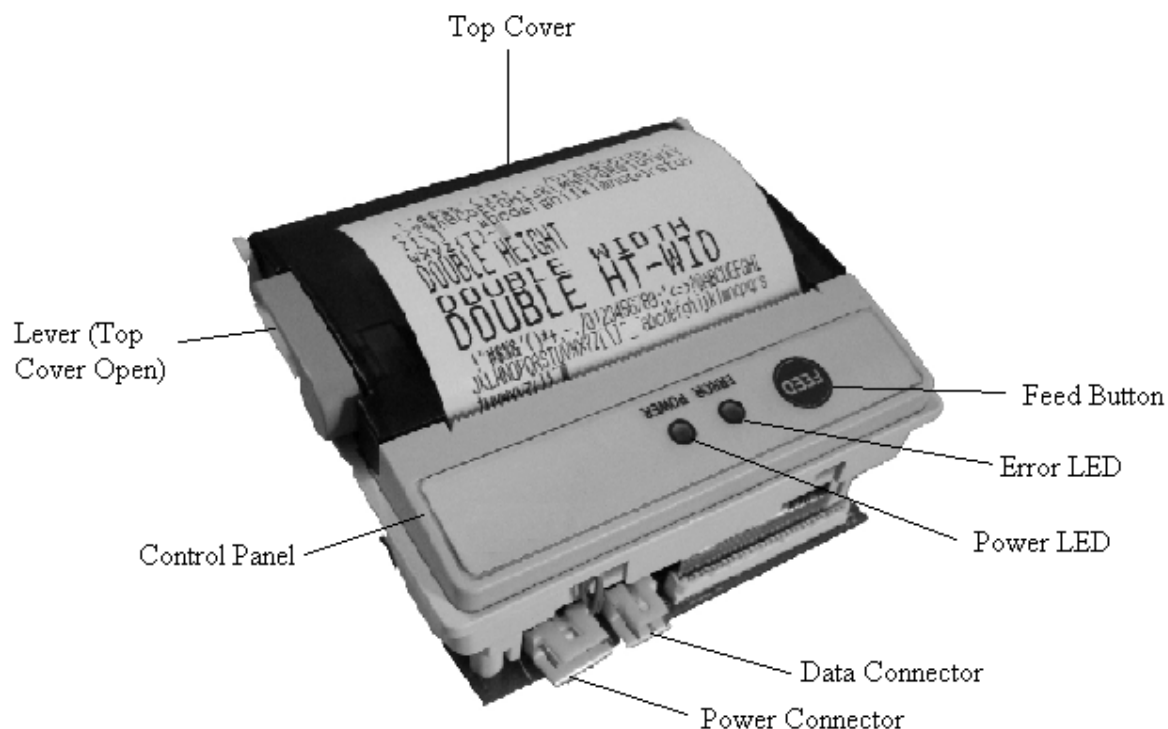

## SPECIFICATIONS

1. Printing Method : Direct Thermal Printing.
2. Print Width : 48 mm
3. Print Speed : 50mm per second
4. Resolutions : 203 DPI (8 dots/mm)
5. Paper Loading : Easy 'Clam Shell' type
6. Characters per line : 29 (default) or 42
7. Character set : 96 Characters ASCII (As shown below) :  
 !"£\$%&'( ) \* + , - . / 0 1 2 3 4 5 6 7  
 8 9 : ; < = > ? @ A B C D E F G H I J K L M N O  
 P Q R S T U V W X Y Z [ \ ] ^ \_ ` a b c d e f h i j k  
 l m n o p q r s t u v w x y z ° # ~
8. Fonts : Normal, Double Width, Double Height & Quadruple Size
9. Sensors : 'No Paper' sensor
10. Paper Type : Direct Thermal Paper
11. Paper Roll : Width 58mm.

		Outer Diameter 40mm
12.	Reliability	: MCBF 50 km
13.	Interface	: RS-232C
14.	Data Buffer	: 768 Characters
15.	Power	: Logic 5VDC @ 250mA Mechanism 8.5 VDC @ 1.5A (Peak 3A)
16.	Cutter	: Manual
17.	Dimensions	: External 80(W) x 76(L) x 43(H) mm Panel Cut-out 76.2 x 72mm

### **PRINTER MOUNTNG METHOD**

#### 1) User side dimension guide

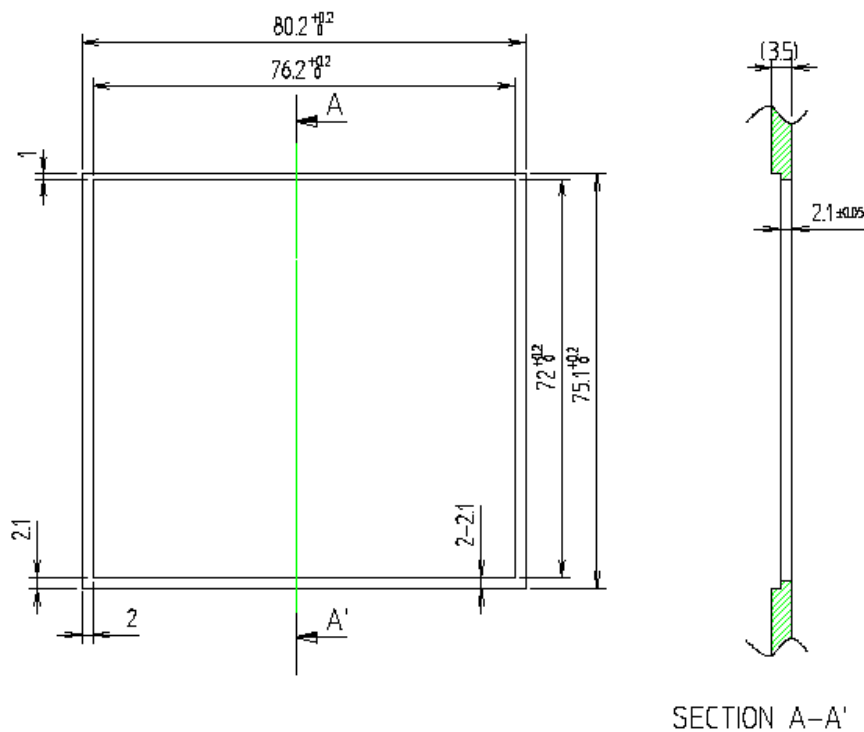

## 2) Mounting flow chart

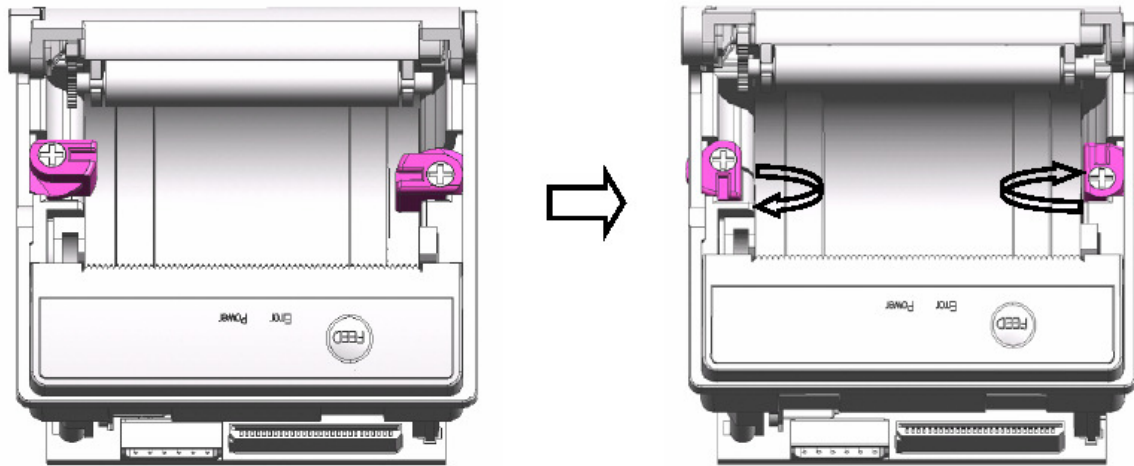

## OPERATING CONTROL PANEL

### Feed Button :

- 1) Press the feed button to advance the paper.
- 2) Feed button can also be used for printing 'Self Test' as follows.  
Hold down the feed button & turn on the printer with Top Cover closed.

### Indicator Lights

- 1) Power  
The 'Power' LED is on when the printer power is on.
- 2) Error  
The error LED blinks is on when paper is out.

## INSTALLING THE PAPER ROLL

Note : The printer must be turned off before installing the paper roll.

- 1) Open the printer cover by pulling the lever.
- 2) Insert the paper roll as shown below

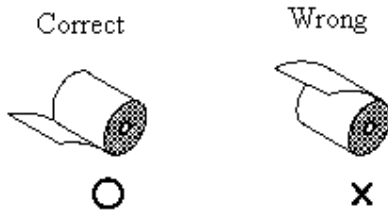

- 3) Pull out the paper until it comes out from the top of the printer. Then close the Top Cover

## IMPORTANT

The power supply should be designed to provide an **instantaneous** peak current of 3 Amps.

The 8.5 Volts power supply to the print head should not be applied in the absence of the 5 Volts Logic power supply.

## SERIAL INTERFACE

1. **Baud Rates** : 9600 Factory set. Any other on special request.
2. **Data Length** : 8 Bits. (Factory set)
3. **Data Buffer** : 768 Characters.
4. **Parity setting** : Absent (Factory set)
5. **Handshaking Signals** : The card gives out a BUSY signal. When the card is ready to accept a data byte, the BUSY line is at about +9 volts. When it is unable to accept any data, this line goes to about -9 volts.
6. **Data Voltage** : RS-232 Levels.
7. **Serial Interface Connection**

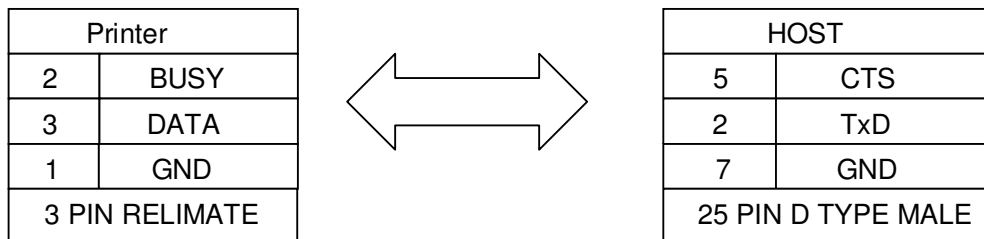
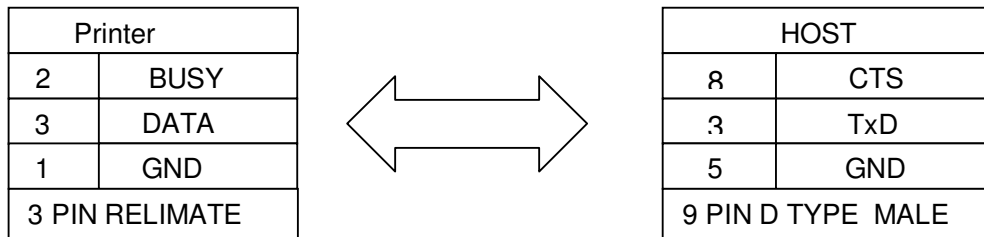

- Note:**
- 1) Short Together DCD, DTR and DSR on your host connector.
  - 2) Transmit data to the Printer after turning on the power and initializing the printer.
  - 3) In 9 PIN D TYPE MALE Connector, DCD, DTR, DSR have following pin Numbers:
    - i. DCD (1)
    - ii. DTR (4)
    - iii. DSR (6)
  - 4) In 25 PIN D TYPE MALE Connector, DCD, DTR and DSR Pin Number as follows :
    - i. DCD (8)
    - ii. DTR (20)
    - iii. DSR (6)

\*\*\*\*\*

## (SELECT PRINT MODE) COMMAND

The format of this command is :

**Esc ! n**

1BH 21H n

Depending on logic levels of the bits in 'n' various print formats can be selected.

Bit 7	Bit 6	Bit 5	Bit 4	Bit 3	Bit 2	Bit 1	Bit 0	
0	0-upright	0- Single width	0- Single height	0	0	0	0	- 29 Cols
0	1-inverse	1- Double width	1- Double height	0	0	0	1	- 42 Cols

## GRAPHIC MODE

It is selected by following command

**Esc X 4 x y d1 d2 ..... d ( k-1 ) dk**

**1BH 58H 34H x y d1 d2 ..... d ( k-1 ) dk**

**ESC X 4 X Y d1 d2 ..... d ( x \* y )** Defines a user-defined bit image using  $x * 8$  dots in horizontal direction and  $y$  dots in vertical direction .

### Range

-Horizontal directions dots =  $( x * 8 )$ dots.

Where  $x$  ranges from 1 to 48.

-Vertical direction =  $y$  dots.

### Explanation:

The graphic pattern to be printed is divided into columns, each column of 8 bits. In this command  $x$  is number of 8 bits columns. The maximum value of  $x$  is 48D.  $y$  is total number of rows.

## LINE FEED

Sending 0AH or 0DH will cause the contents of the data buffer (if there are any) to be printed followed by a line feed. If there is no data in the buffer, then a simple line feed will occur.

In graphic mode these will NOT cause line feed. They will be interpreted as data bytes.

## **COMMAND SETTING**

Factory Set : 1 Start bit, 8 Data bit, 1 Stop bit, No Parity, Baud Rate 9,600 bps.\*\*\*

Any other on request

## **CONNECTORS**

### **6 PIN RELIMATE (MALE) FOR POWER & DATA.**

- 1) Power GND (Black) 2) BUSY (Yellow) 3) DATA (Orange)
- 4) +8.5VDC (Red) 5) +5VDC (Brown) 6) GND (Green)